



PCR Cabinet HUYAir PCR Elite

- ✓ Complies with IEST, ISO 14644-3:2019 standards
- ✓ LCD control
- ✓ DC motor
- ✓ Warranty: 3 years

PURPOSE

To prepare PCR reactions and various other molecular biology methods, a contamination-free working environment is necessary. The HUYAir PCR | PCR Cabinet is designed for decontaminating DNA/RNA in the laboratory workspace.

TECHNOLOGY

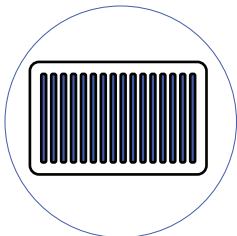

Camfil filters - Sweden
or AAF filters - USA

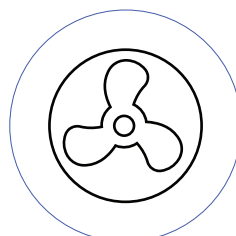

DC Centrifugal Fan
EBMpapst - Germany



LCD control

- HUYAir PCR uses a control system with the "HUYAir Comprehensive" processor, displaying the full performance of the hood on the LCD screen.
- Airflow Monitoring: The cabinet is equipped with sensors to directly monitor airflow rates and includes a low airspeed alert feature.
- Filter and UV Lamp Alerts: It provides alerts when the filters and UV lamps have reached the end of their service life.
- Safety Features: Safety features include automatic UV lamp shutoff when the cabinet is opened, door alerts when the glass is opened beyond 200mm, and motor reduction to 30% when the glass is completely closed for energy efficiency and prolonged motor life.
- EBMpapst DC Centrifugal Fan: The cabinet uses a powerful and energy-efficient DC centrifugal fan from EBMpapst in Germany, designed to minimize noise while ensuring efficient air circulation.
- Camfil or AAF Filters: It utilizes Camfil filters from Sweden or AAF filters from the United States, providing high-efficiency H14 filtration, capturing 99.999% of particles at 0.3 micrometers.

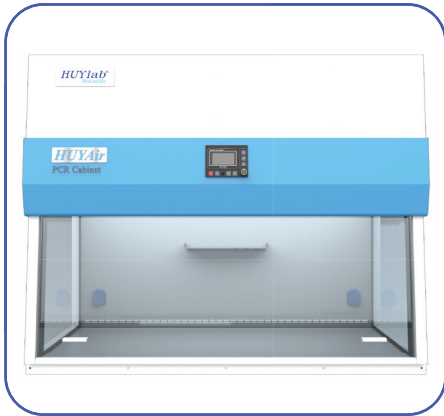

DESIGN

- The cabinet is designed with 5mm tempered glass on both sides to protect against ultraviolet rays and to allow easy observation of samples and the user's processes.
- HUYlab's PCR Cabinet is designed for user-friendly and convenient operation, with an intelligent design that optimizes weighing and efficiency.

MATERIAL

- The door material consists of 5-10 mm toughened glass
- The outer shell is made of 1.2 mm thick galvanized steel, electrostatically painted to resist chemicals and UV.
- The inner chamber is made of 1.2 mm thick galvanized steel, electrostatically painted to resist chemicals and UV.

AIR FLOW SYSTEMS

- The air in the room is drawn in from above the cabinet through the main HEPA filter.
- The air is uniformly pushed through the HEPA filter to create a clean and consistent airflow in the workspace. The filter's face velocity is 0.3 m/s (90 fpm), ensuring a sufficient air exchange rate in the workspace to eliminate cross-contamination and maintain optimal cleanliness.
- The clean air moves through the workspace to the working surface in a unidirectional flow and then exits the workspace through the front-open cabinet.

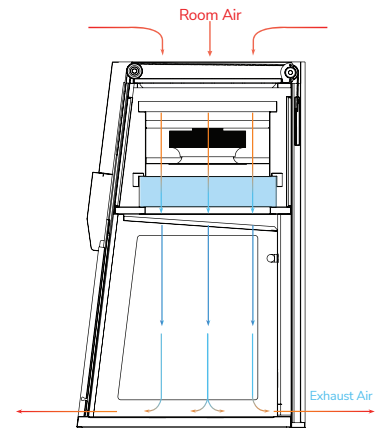

SPECIFICATIONS

Model	HUYAir PCR-700 Elite	HUYAir PCR-900 Elite	HUYAir PCR-1200 Elite
External dimensions (LxWxH)	L710 x W675 x H1070 mm	L1040 x W700x H1070 mm	L1325 x W700 x H1070 mm
Internal dimensions (LxWxH)	L620 x W565 x H580 mm	L950 x W580 x H580 mm	L1255 x W580 x H580 mm
External dimensions with Support stand (LxWxH)	L710 x W675 x H1790 mm	L1040 x W700 x H1790 mm	L1325 x W700 x H1790 mm
Air flow velocity	0,3 m/s		
Lighting intensity	>750 lux		
Noise level	<65 dB		
Input voltage	220 V/50 Hz		



ACCESSORIES

HUYlab provides a range of accessories designed to be compatible with various cabinet models for different applications.

Support stand	Mobile Frame Stand with Wheels, Designed for Model
	Fixed Cabinet Base Stand, Designed for Model
Filter Accessories	Filter ULPA (H15)